

RD1

DOUBLE RAMP

Electric and manual hybrid ramp in one unit

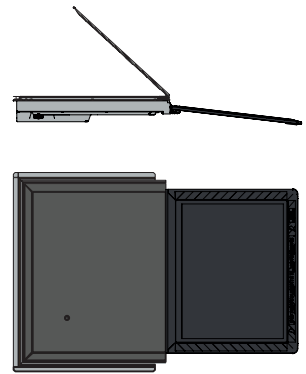

DESCRIPTION

The module combines the functionality of an electric ramp and a manual ramp, always ensuring uninterrupted vehicle availability.

Includes a practical electric ramp placed under the floor, together with a manual ramp integrated in the vehicle floor.

Includes sensitive edge and step detection sensor for utmost safety.

It detects any obstacle placed in the front of the ramp. In this case, the ramp automatically moves in.

The platform is sensitive to weight, both in static and in dynamic phase. When detecting a weight heavier than 15 kg, it remains immobilized in the static phase, and it stops in dynamic phase. The ramp retries automatically.

Made entirely of aluminium and stainless steel. Manual ramp includes a lockable handle. A proximity Switch ensures safety, as it signals to the driver that the ramp is not folded.

ADVANTAGES

- Total availability, the manual ramp can be used when the automatic ramp is not working for any reason, offering total service.
- Simplicity of operation.
- Total integration in the floor level, flush mounted design.
- Once the platform is extended, it remains at the vehicle's floor level.
- Easy maintenance.

Option: Integration of side lighting in the ramp (only with ECU Evolution).

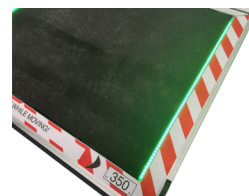

RD1

DOUBLE RAMP

Electric and manual hybrid ramp in one unit

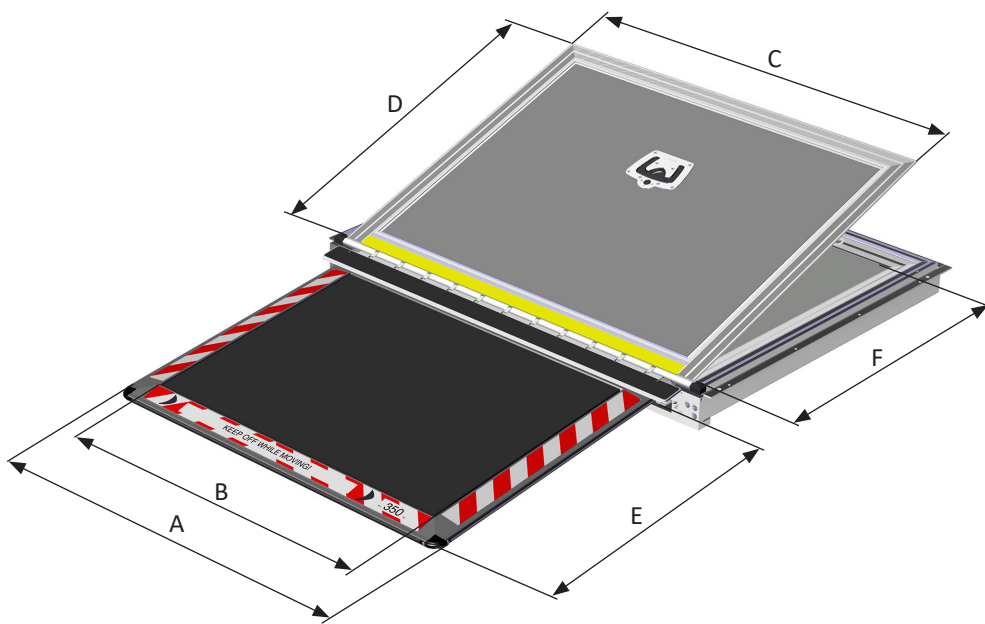

A	920 mm
B	800 mm
C	1.015 mm
D	825 mm
E	735 mm
F	875 mm

TECHNICAL DATA

- Total weight: 70 kg
- Load: 350 kg
- Pursuant to regulations R107 and R118.

